

ELECTRONIC ROTATION CONTROL

WORKING PRINCIPLE

This device measures the time gap between two signals from a sensor on a revolving or cycling mechanism. When the time gap becomes greater than the pre-set value, the device signals a drop in velocity or full stop of the mechanism's movement.

The rotation controls come in two types CRTP, which has the controls separate and requires a sensors or CRT30 that has the sensors and controls in one housing.

These units are ideal for control of slipping transport belts, chain breakage, power interruption or overloads etc. Applications include belt transport, chain elevators, mills, grinders, pumps, kneading mixers and other situations where movement control of revolving or cycling mechanisms is necessary.

CRTP

This device is composed of a central electronic unit that plugs into a socket and an inductive, capacitive or photoelectric sensor. Since the sensor is separate, any number of sensors can be used allowing for this unit to operate in a number of applications.

PROGRAMMABLE FUNCTIONS, CRTP

1) TIME AND RPM T1

The time/RPM ranges from 0.03 - 512 sec / 0.1 - 2400 RPM distributed on nine scales that are selected by means of the front mounted dipswitches. The selected scale is adjusted by means of a potentiometer T1.

It is possible by summing two or more scales to obtain full scale values, which are different from the standard ones. This is obtained by placing the switch with the values pre-selected in the ON position (Example: switches. 2 and 4 ON position, corresponds to a full scale of 144 seconds). This operation can also be carried out on the RPM scale. For the conversion, time/RPM see chart 1 at page 53.

2) INITIAL DELAY T2

Is an initial delay period before the unit becomes active, 0.3-10 sec. This allows the rotating parts to reach their normal working speed.

3) FUNCTION A-B

When the CRTP gives out a signal of standstill or slowing down, it is possible to have two types of functions that can be selected by switch number 10 ON/OFF.

A: In order to reactivate the unit it is necessary to switch the power supply off and then on to reset.

B: The unit can be reactivated by means of the first impulse that arrives from the sensor or by means of the reset. This is obtained with the switch in the OFF position.

4) SENSOR - NAMUR - NPN - PNP

It is possible to select via the switch number 11 in the ON/OFF position the type of logic for the sensing unit. In the ON position, it is possible to connect NPN sensors and in the OFF position PNP and NAMUR sensors.

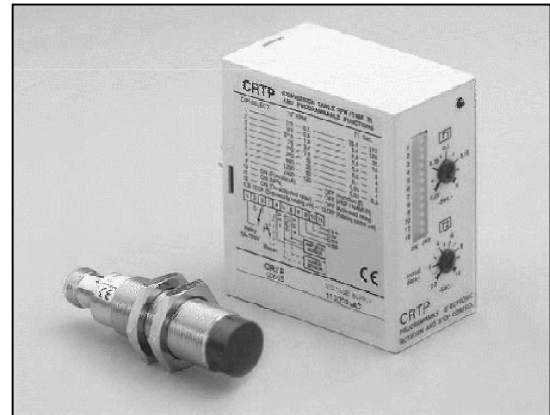

5) ROTATION CONTROL - SHAFT STAND STILL

Switch number 12 controls these functions.

5a) ROTATION CONTROL - SWITCH OFF

With power applied, the relay switches and maintains this position as long as the impulses from sensors are received within the set time. If within that time no impulse is received the relay changes state giving an alarm condition, in the case of lack of power supply the relay changes state (see working diagram) giving the alarm condition (slowdown or stopping).

5b) SHAFT STAND STILL CONTROL - SWITCH ON

In this situation, the relay works in exactly the opposite way. The relay activates when no impulse arrives within the set time thus showing the shaft standstill condition. In the case of loss of power supply the relay changes state thus giving the alarm condition (shaft movement).

CRT30

The CRT30 is a combination of a 30mm diameter inductive sensor and rotation control device. The operating distance of the sensor is between 4 and 6 mm on metallic material. The wide power supply range (18-50 DC and 18-240 AC), various programmable functions, and output relay make of this device suitable for a variety of applications.

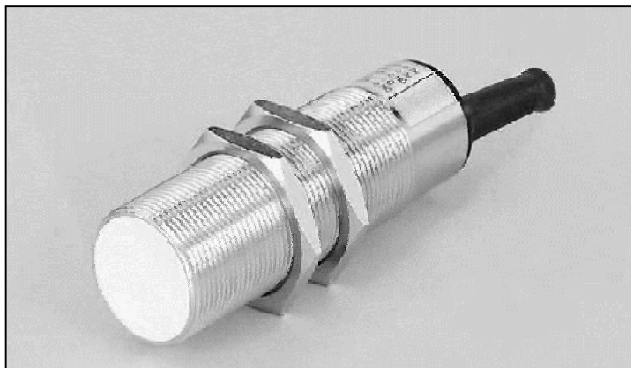

PROGRAMMABLE TYPES AVAILABLE

CRT30-R10L = 6-150 RPM detectable by means of trimmer. Functions A and B available by means of selector.

CRT30-R10V = 120-3000 RPM detectable by means of trimmer. Functions A and B available by means of selector.

CRT30-R10L/V = two range of RPM can be detected (6-150 RPM and 120-3000RPM) and selected by means of trimmer regulator. Function B pre-programmed and fixed.

Function types A-B: when CRT30 detects full stop or velocity decrease you can have two working functions (excluding type CRT-R10 L/V):

A: In order to reactivate the unit it is necessary to switch the power supply off and then on to reset.

B: The device re-activates itself automatically as soon as the number of rotations exceeds alarm range.

Controls

PROGRAMMABLE ELECTRONIC ROTATION AND STOP CONTROL

PROGRAMMABLE FUNCTIONS
 RPM RANGE PROGRAMMABLE FROM 0.1 TO 2400 Imp./min.
 COMPATIBLE WITH INDUCTIVE, CAPACITIVE, PHOTOELECTRIC AND HALL SENSORS
 12Vdc OUTPUT TO POWER SENSORS
 RELAY OUTPUT

MODEL	S3426 CRTP 24Vdc/ac	S3427 CRTP 110/220Vac
	<p style="text-align: center;">INDUCTIVE SENSORS CAPACITIVE SENSORS PHOTOELECTRIC SENSORS HALL EFFECT SENSORS OTHER SENSORS</p>	
Power Supply	24Vdc/ac	110/220Vac
Rotations Range	0.1 – 2400 RPM	
Time Range	.03 – 512 sec	
Initial Delay T2	0.3 – 10 sec.	
Function A	Programmable DIP SWITCH 10 = ON	
Function B	Programmable DIP SWITCH 10 = OFF	
Max Power Drain (relay on)	1.5 VA	
Output Power	12 Vdc	
Max supply current	50 mA	
Relay	Form C, 5A –240VAC (resistive load)	
LED	Yes	
Temperature	-20 to +60 °C	
Protection degree	IP40	
Housing	Plastic	
Connection	11- pin socket	
Mating mounting socket	Model: S3429 B11 mounting socket (page 55)	
Fixing spring for mounting	Model: S3430 MF fixing spring (page 55)	

CONVERSION TABLE RPM/TIME AND PROGRAMMABLE FUNCTIONS

DIP SWITCH position	Number of RPM	T1 Seconds	Chart 1	
1	2,3	0,1	25,6	512
2	9,3	0,4	6,4	128
3	37,5	1,8	1,8	32
4	75	3,7	0,8	16
5	150	7,5	0,4	8
6	300	15	0,2	4
7	600	30	0,1	2
8	1200	60	0,05	1
9	2400	120	0,03	0,5
10	ON (A FUNCTION)	OFF (B FUNCTION)		
11	ON (NPN SENSOR)	OFF (PNP/NAMUR SENSORS)		
12	ON (SHAFT STANDSTILL)	OFF (ROTATION CONTROL)		

N.B. The positions from 1 – 9 (Preselection ON) program the time or RPM ranges. Positions 10-11-12 program the available functions.

ON ↔ OFF

WIRING

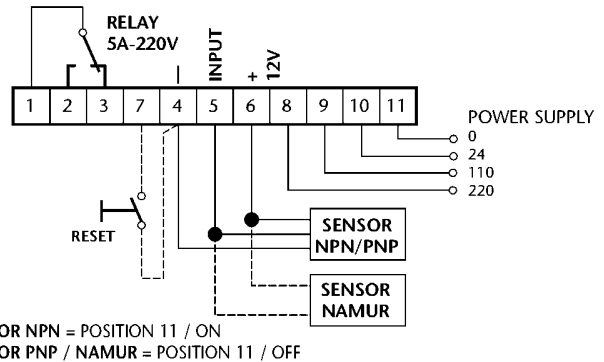

WORKING DIAGRAM

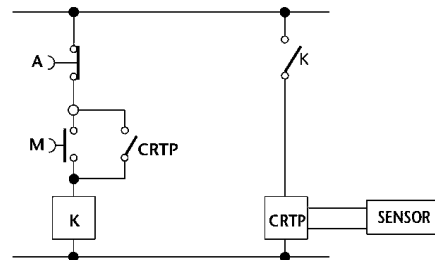
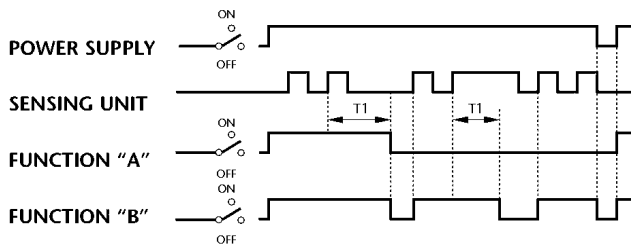

INDUCTIVE ROTATION CONTROL CRT30

CONTROL UNIT AND SENSOR IN ONE UNIT
RELAY OUTPUT
VERSION WITH PROGRAMMABLE TIME RANGES OR OUTPUT FUNCTION

MODEL	S3431 CRT30 – R10L	S3433 CRT30 – R10V	S3432 CRT30 – R10L/V
Power Supply	18 – 50 Vdc / 18 – 240 Vac		
Rotations Range	Low (L) 6 – 150 RPM	High (V) 120 – 3000 RPM	Programmable by switch
Time Range	6 imp./min. Tr = 10 sec 150 imp./min. Tr = 0.4 sec	120 imp./min. Tr = 0,5 sec 3000 imp./min. Tr = 0,02 sec	Programmable by switch
Initial Delay	9 – 15 sec		
Function A	Programmable by switch		No
Function B	Programmable by switch		Yes
Max Power Drain (relay on)	20 mA		
Relay	Form C, 1A –240Vac (resistive load)		
LED	Yes		
Temperature	-20 to +70 °C		
Protection degree	IP65		
Housing	Nickel-plated brass		
Connection	Cable PVC: L = 2 m		

INSTRUCTION FOR CORRECT INSTALLATION

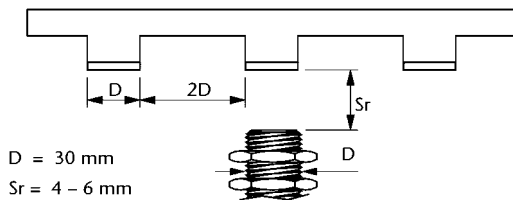

WIRING

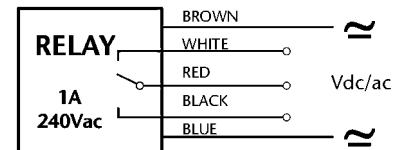

Multivoltage power supply
18–50 Vdc / 18–240 Vac

WORKING DIAGRAM

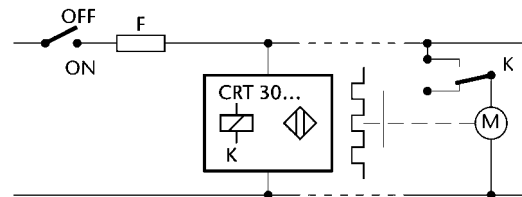
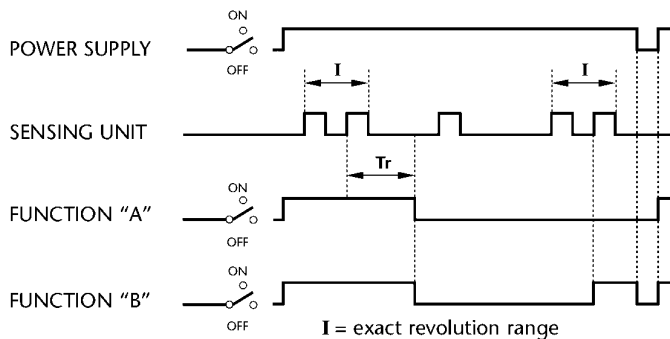

Controls

ACCESSORIES

SOCKET FOR AMPLIFIERS - POWER SUPPLIES

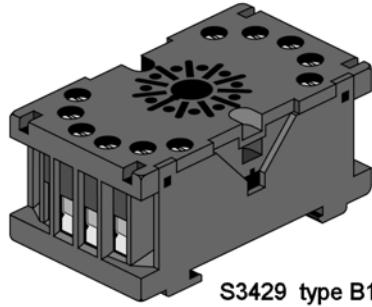

S3429 type B11

socket for panel or DIN rail mounting.

FIXING SPRING S3430 MF

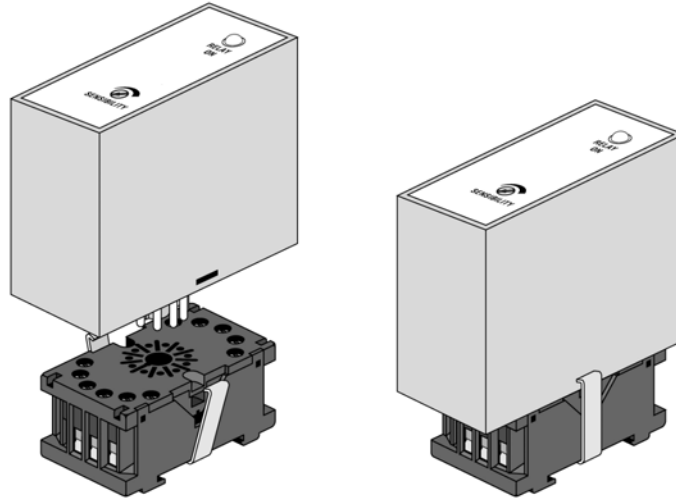
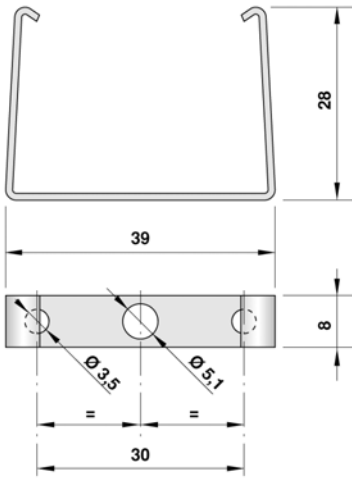

For a correct fixing of the units it is recommended to use socket S3429 type B11 with fixing spring S3430 MF.