

RS-84-5 Ratchet Counter



FEATURES:

- Highly visible 5 digits
- Long mechanical life
- Reset Knob
- Great price
- High speed

DESCRIPTION:

The RS-84-5 offers highly visible 5 digits, small footprint and long mechanical life. Its price and features make it well suited for OEM equipment. This ratchet counter adds 1 count for every 40°~45° stroke of lever.

Typical applications include tool machines, winding machines, automatic machines, presses, shearing machines, printing machines, measuring of tape, rope, extruded material, etc...

SPECIFICATIONS:

Model	RS-84-5
Function	Ratchet: Adds 1 count for every 40°~45° stroke of lever.
Digits	5, high contrast white on black
Figure Size	0.2" x 0.1"
Shaft Diameter	.157"
Shaft Position	Right side
Direction	Top going
Reset	Knob: rotating of knob
Max. Speed	400 cpm
Housing	Metal base; Plastic cover, lens and reset knob
Weight	2.5 oz

DIMENSIONS: inches

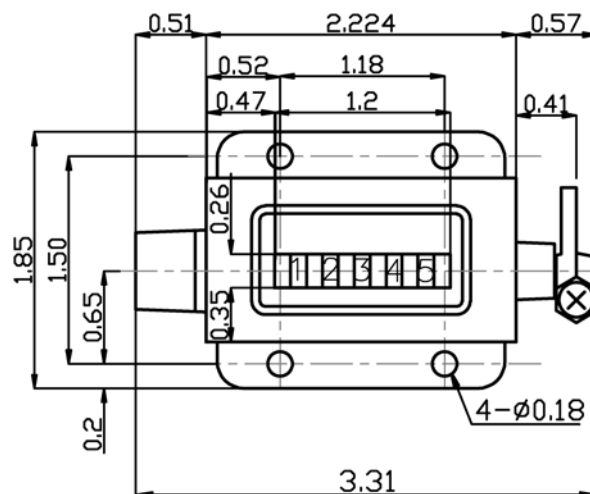

TOP GOING

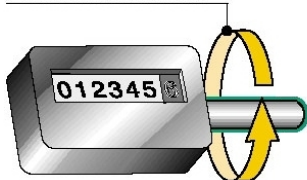

SHAFT OUTPUT
RIGHT

